

The enclosed self-tapping screws will suit most latch fitting situations. For non-standard or difficult applications, consult your hardware expert to obtain suitable, non-corrosive fixings. *Use countersunk style fixings only where designated.*  
As with all "mechanical" gate latches, LOKK•LATCH is not recommended for use on pool gates and other child safety areas. Use MAGNA•LATCH® magnetic safety gate latches for these applications.

### INSTALLATION PROCEDURE

- This latch is designed to be fitted to the inside (house side) of the gate.
- Ensure the gate frame and the latch post are in alignment (no offset). See dotted line No. 1.
- If installing an External Access Kit, ensure the Striker Body is fitted flush with the outside of the gate frame (see dotted line 2).

1. Determine the approximate height of the latch on the inside of the gate (house side).

2. Locate the Striker Body on the gate frame so that the bolt side of the molding aligns with the outside of the frame (see dotted line No. 2). Hold the Striker Body in position and mark gate through the fixing holes.

3. Remove the Striker Body and drill pilot holes using a drill bit suitable for your fence material.

4. Secure the Striker Body to the gate using the two pan-head screws (with washers) and four countersunk 1/2"x8g (12mmx8g) supplied.

5. Close the gate. Align the main Latch Body on the latch post so that the Striker Bolt will close in the centre of the latch tongue (i.e. align the Striker Bolt with the centre of rivet).

6. Remove the Latch Body and drill pilot holes where marked using the appropriate drill bit. Secure the Latch Body using the 1/2"x8g (12mmx8g) countersunk screws supplied.

7. Check latching operation to ensure smooth, reliable closure. Your LOKK•LATCH is now ready for use.

**MAINTENANCE:** REMOVE KEY/S FROM LOCK/S AFTER USE. Do not lubricate any part of this latch. Ensure all screws are tightened firmly and that the Latch Body and/or Access Kit is kept free of dirt, sand and other debris which could impair reliable performance.

**WARRANTY & LIMITATION OF LIABILITY:** The products are warranted to be free of defects in materials and workmanship to the original purchaser for as long as he/she owns the product. If a defect appears, the original purchaser may return the item, freight prepaid, together with proof of purchase to the company or its approved international agents. The company or agent will, at its discretion, repair or replace the defective item or part without charge to the purchaser. THIS WARRANTY SHALL NOT APPLY WHEN the product has been tampered with, when repairs or attempted repairs have been made by unauthorised persons, where the item has been subjected to misuse, abuse, accident or damage in transit, or where the installer has not followed the instructions set out during installation or operations. No charges will be accepted for unauthorised parts, repairs or services. IN NO EVENT SHALL THE COMPANY BE LIABLE FOR ANY INCIDENTAL OR CONSEQUENTIAL DAMAGES. No warranty is given other than that set out above. No express or implied warranties (including statutory warranties) apply, other than warranties which may not legally be excluded. LLINSTR0010PA

### LEFT OR RIGHT GATE OPENING?

The latch is supplied to fit right-hand posts. To adapt latch to fit left-hand posts, remove the six screws from rear of the Post Bracket and rotate bracket 180°. Replace screws firmly.

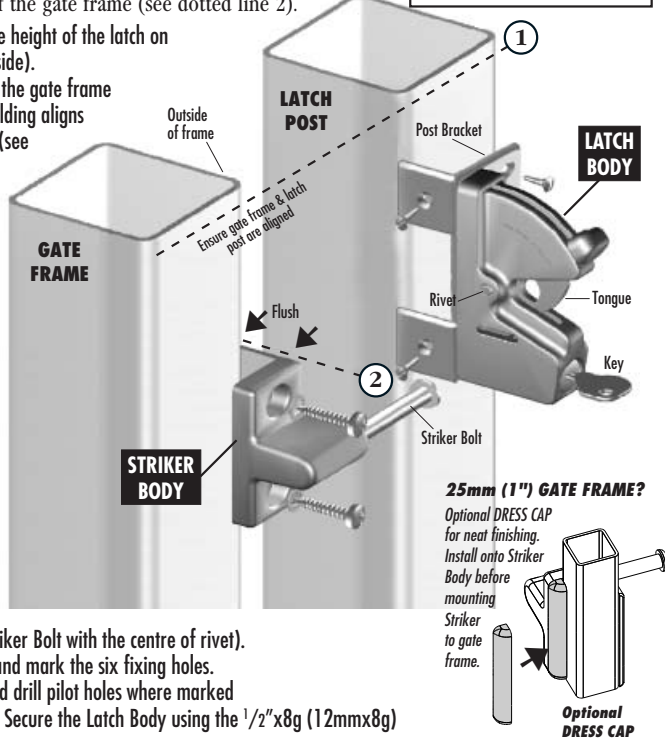

The 'External Access Kit' allows a gate to be opened and locked from *outside* the fence. When installed, it is connected to the main latch (inside the fence) by an adjustable push-rod.

### INSTALLATION PROCEDURE

1. Prop gate open. Open latch by sliding the release knob to rear of housing. Take the stainless steel push-rod, and, holding it vertically with adjustable end down, feed the Adjustor Lever through the slot in the side of the Latch Body (as shown by the arrow).

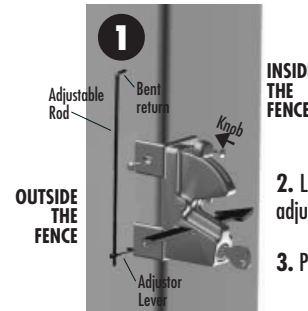
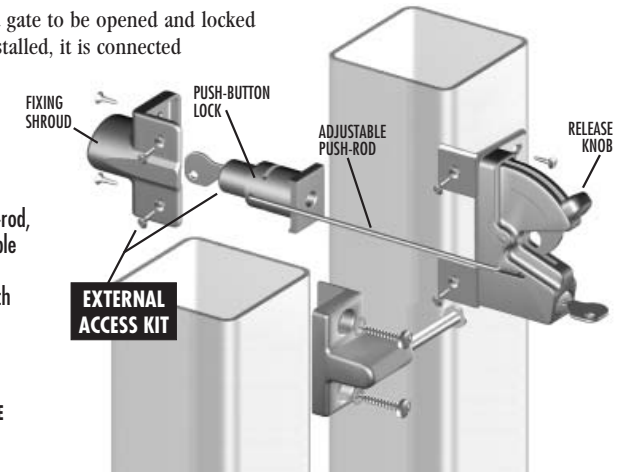

2. Lower the release knob so that it 'encloses' the adjustor lever. Turn the key to lock the knob.

3. Pivot/rotate rod to the outside of the fence.

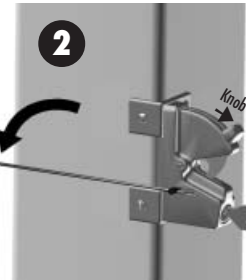

4. In preparation for adjusting the push-rod to the required length, ensure the rod is kept *level* at all times. Place the Push-Button Lock flat against the fence post, as shown in diagram 3. Keeping the Lock in place, adjust the rod to the correct length by screwing the bent 'return' until it aligns with the hole at the side of the Lock ('A'). It is *very important* the rod is *adjusted fully*; check this by ensuring there is no "play" (looseness) of the rod once adjusted — see inset 'B'.

5. With the correct rod adjustment determined (and marked) remove the entire rod from the Push-Button Lock and the Latch Body and cut off any excess thread length to approximately 6mm (1/4") from the adjustor lever. File off any sharp edges to make smooth.

6. Re-install the push-rod through the Latch Body and then insert the bent return into the hole at the side of the Push-Button Lock (further minor screwing adjustment may be required to ensure there is no slack).

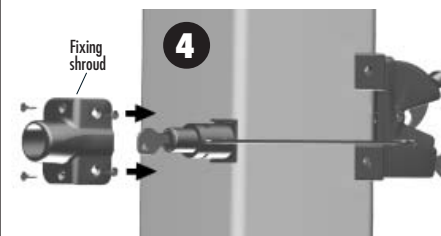
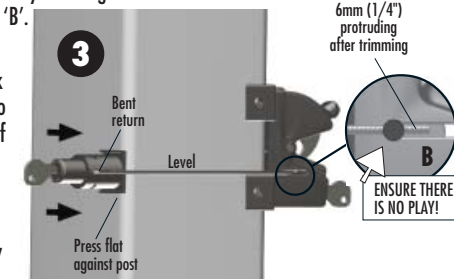

**Note:** WHEN LOCKING EXTERNAL ACCESS KIT, DO NOT LOCK INSIDE LATCH.

7. Take the Fixing Shroud and slide it over the Push-Button Lock (see left). Again, ensure push-rod is kept level to guard against binding. Drill 'pilot' holes and fasten the Fixing Shroud to the post using the 12mmx8g (1/2"x8g) countersunk screws supplied.

### LOKK•LATCH INSTALLED

